

## FGP 50/M EVO

Light-oil burners two stages progressive or modulating operation (if equipped with addition of optional modulation kit PID and probe; to guarantee an ideal proportionality of the power supplied to the thermal load).

Composed by: fan at high pressurisation at reverse blades and combustion head with adjustment at high efficiency and high flame stability.

Compact overall dimensions and disposition rationalized of the components with accessibility facilitated for the operations of setting and maintenance.

Complete of nozzle, flexible pipes and line filter.

Complete of flange and gasket for installation on generator.

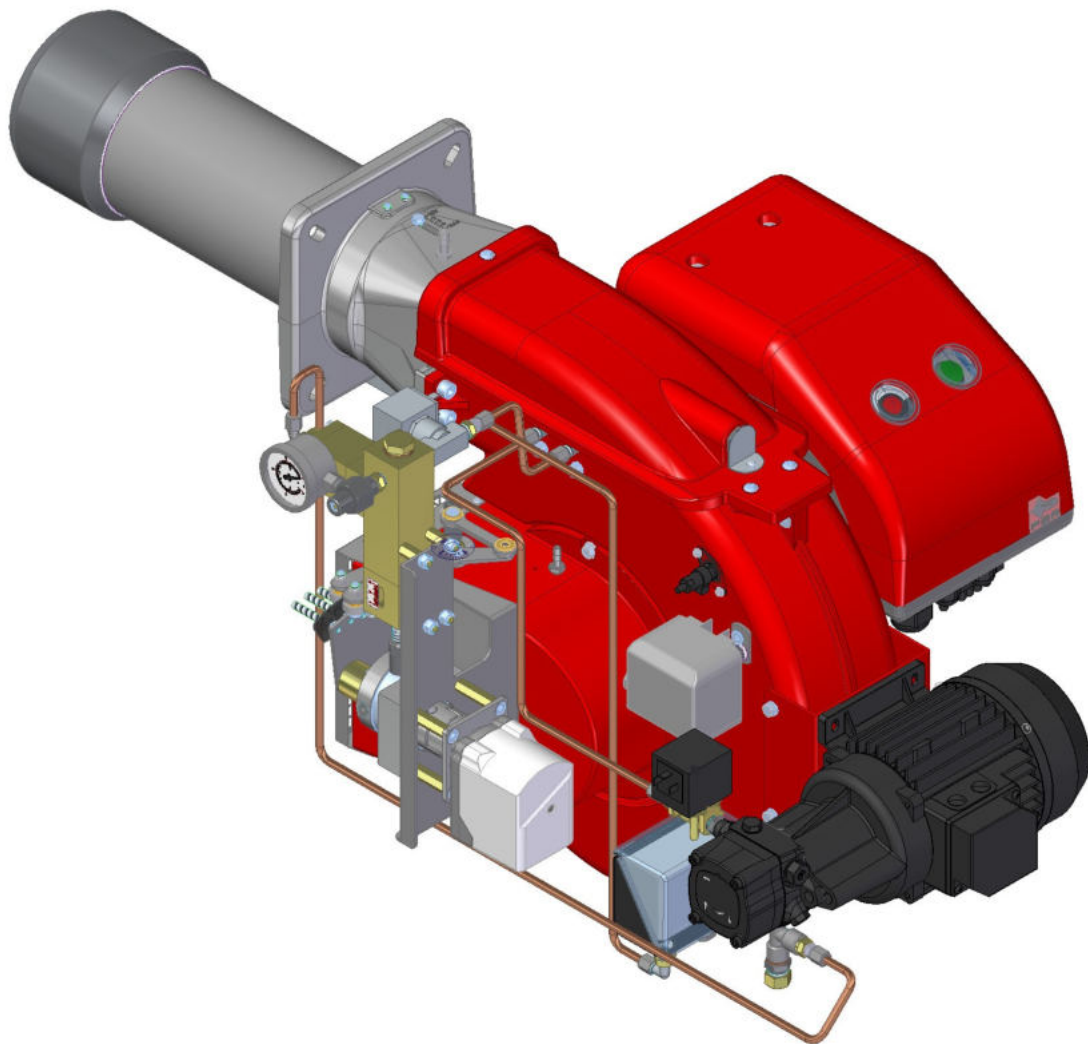

Fig. 1 FGP 50/M EVO

## TECHNICAL DATA FGP 50/M EVO

MODEL		<b>FGP 50/M EVO</b>
Thermal power min. 1°st. / min. 2°st. - max. 2°st. *	[Mcal/h]	107/204-542
Thermal power min. 1°st. / min. 2°st. - max. 2°st. *	[kW]	124/237-630
LIGHT-OIL flow min. 1°st. / min. 2°st. - max. 2°st. *	[kg/h]	10.5/20-53
Fuel:	LIGHT-OIL 1.5°E at 20°C = 6.2 cSt = 35 sec Redwood N°1	
Intermittent working operation (min. 1 stop every 24 hours) two stages progressive or modulating		
Environmental conditions operation / storage:	-15...+40°C / -20...+70°C, rel. humidity max. 80%	
Max. temperature combustion air	[°C]	60
Nominal electric power	[kW]	1.1
Fan motor	[kW]	0.55
Pump motor	[kW]	0.37
Nominal fan motor current absorption	[A]	1.4
Nominal pump motor current absorption	[A]	1.2
Nominal auxiliary absorption	[A]	0.6
Power supply:	3~400V, 1/N~230V-50Hz	
Electric protection degree:	IP44	

\* Reference conditions: Environment temperature 20°C - Barometric pressure 1013 mbars - Altitude 0 metre (sea level).

## OPERATING RANGE DIAGRAM FGP 50/M EVO

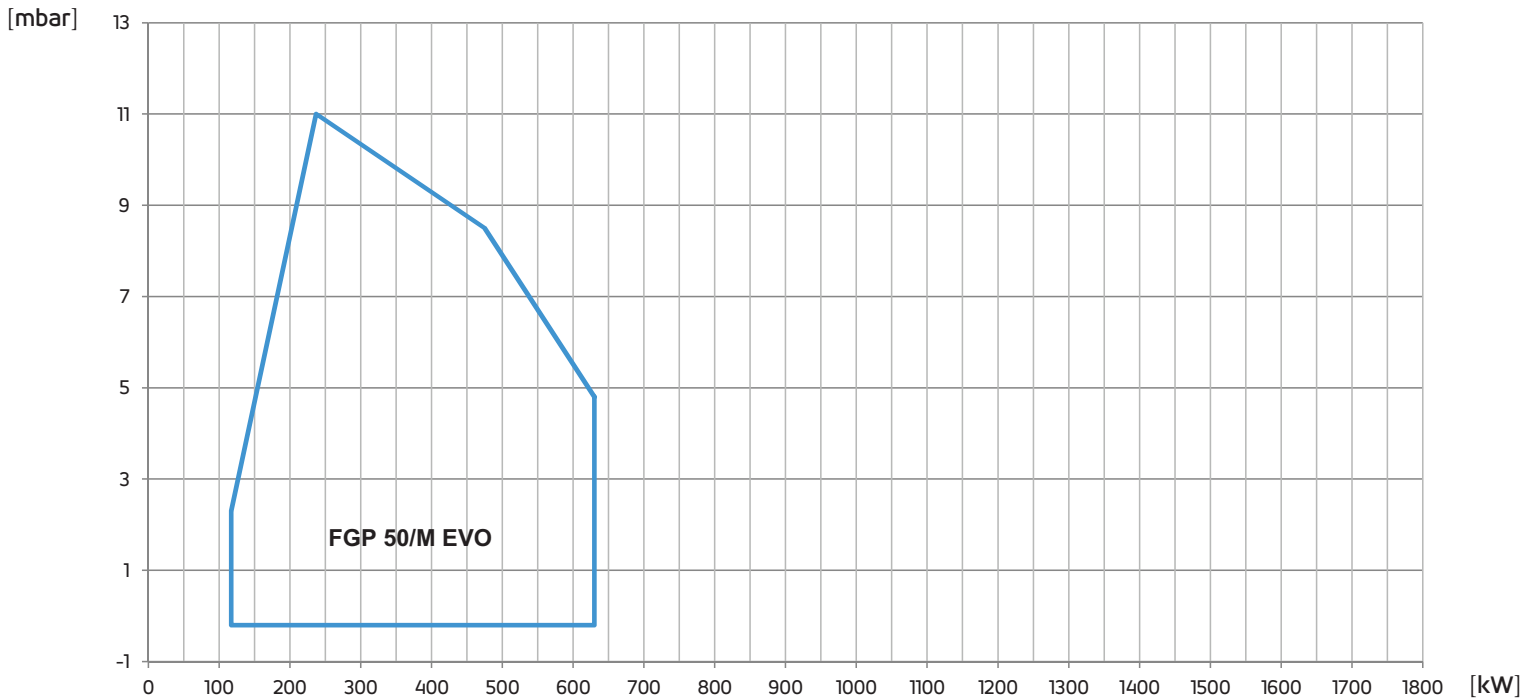

**Fig. 2 X = Thermal power Y = Pression in the combustion chamber**

The firing rates has been obtained based on test boilers in accordance with EN267 standards and are indicative of matching the burner to the boiler. For the correct operation of the burner, combustion chamber dimensions must be in accordance with current regulation. In case of non-compliance, contact the manufacturer.

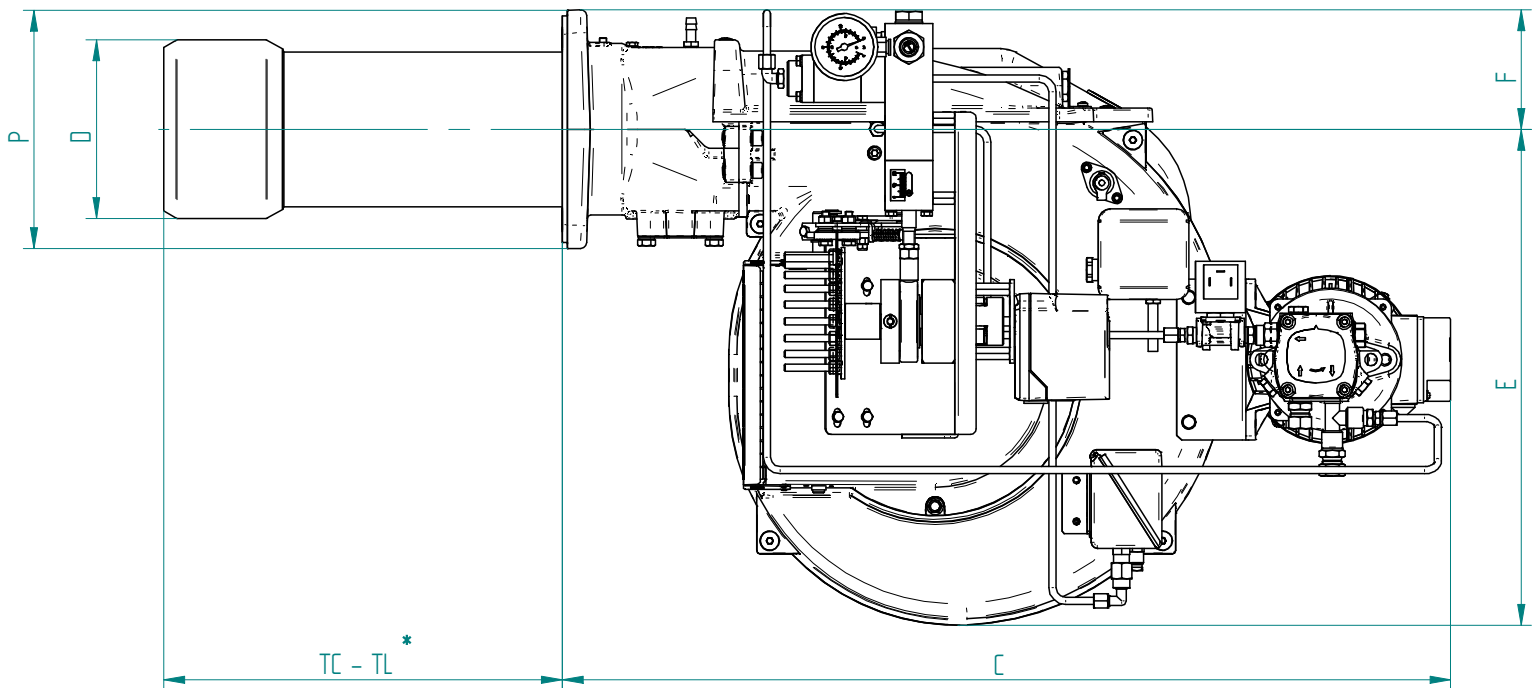
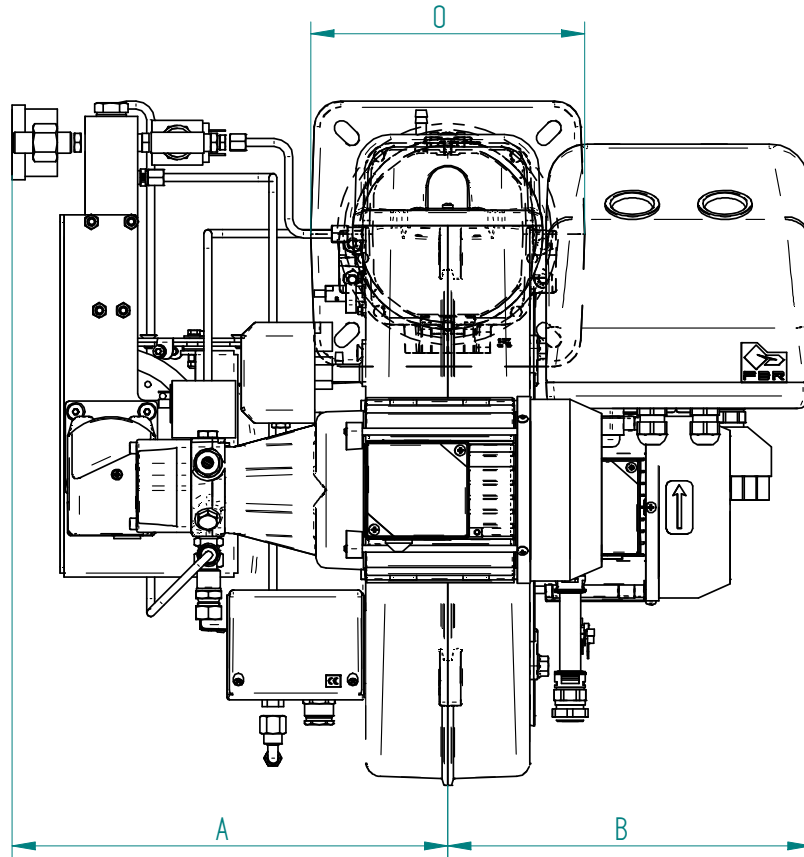

Fig. 3 Dimensions FGP 50/M EVO

MODEL	A	B	C	D	E	F	O	P
FGP 50/M EVO	329	274	746	150	416.5	100	207	200

C2: Overall dimension with the burner out in position of maintenance.

\* see "flame tube length"

**BOILER PLATE**

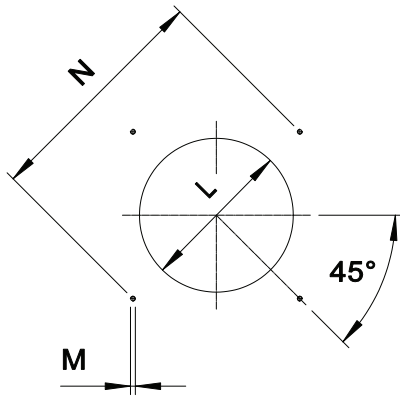

\* Suggested dimension of connection between burner and generator.

Fig. 4 Boiler plate

MODEL		M	N min	N max	L min	L *	L max
FGP 50/M EVO	mm	M10	205	226	160	160	180

**FLAME TUBE LENGTH**

Flame tube length must be selected based on the specifications supplied by boiler manufacturer and, in any case, it must be greater than the thickness of the boiler door included its insulation.  
In case of boilers with flame inversion or front flue combustion chambers, it is necessary to insulate the area between the flame tube and front door with refractory material. This protection material must not impede flame tube extraction.

MODEL		TC	TL **
FGP 50/M EVO	mm	250	335

\*\* For different flame lengths, please contact our Technical-Sales Department.

### BURNER SIGNAL DESCRIPTION

In the picture below there are indicated all the signalation present on the burner:

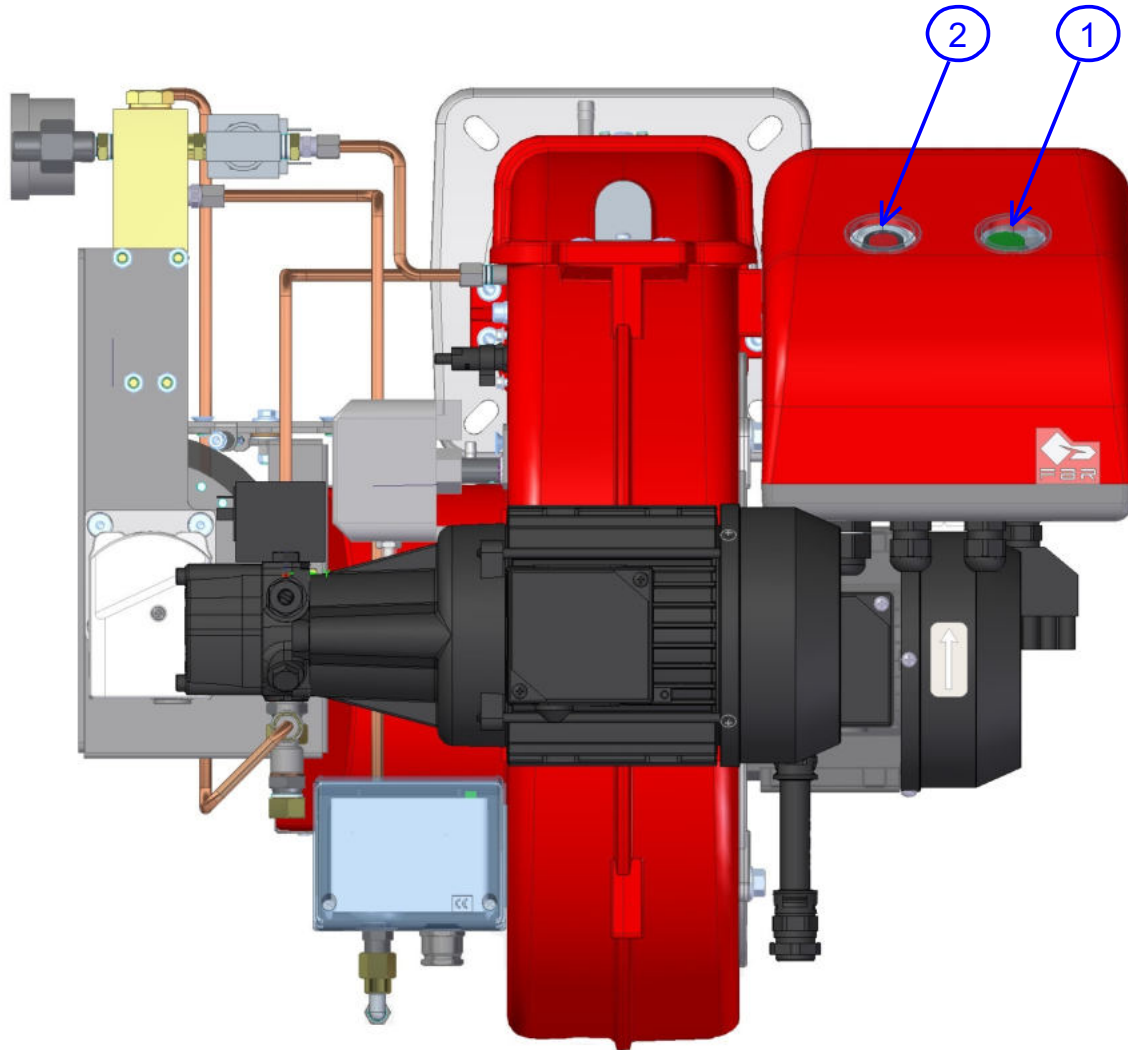

**Fig. 5** Burner signal description

#### LEGEND

1) ON/OFF button

2) Reset from lockout button + status lamp

💡 The multicolor signal lamp in the lockout reset button (pos.2) is the key indicating element for visual diagnostics and interface diagnostics.

In normal operation, the different operating states are indicated in the form of color codes; please refer to electrical device handbook supplied with the present instructions.

💡 After a non-alterable lockout, the red signal lamp in the lockout reset button (pos.2) lights up. By pressing the lockout reset button (pos.2) for more than 3 seconds, the visual diagnostics of the cause of fault can be activated; please refer to electrical device handbook supplied with the present instructions.

For close the diagnostics mode and for switch on the burner again, it is necessary to reset the burner control. Press the lockout reset button (pos.2) for about 1 second (<3 seconds).

💡 After a non-alterable lockout, the red signal lamp in the lockout reset button (pos.2) lights up. For reset the control box press the lockout reset button (pos.2) for about 1 second (<3 seconds).

**PRODUCT SPECIFICATION****SHORT DESCRIPTION**

Light-oil burners two stages progressive (hi-low flame) or modulating (PID fully modulating) if equipped with addition of optional modulation kit and probe.

**DETAILED SPECIFICATION**

Light-oil burner two stages progressive (hi-low flame) or modulating (PID fully modulating) if equipped with addition of optional modulation kit and probe; composed by:

- Fan at high pressurisation at reverse blades;
- Combustion head with adjustment at high performance and elevated flame stability;
- Flange and insulating gasket for fixing at boiler;
- Three-phase power supply;
- Photodiode for flame detection;
- IP 44 electric protection level;
- Servomotor for air shutter and for the pressure regulator;
- Easy extraction of combustion head without get off the burners by bolier;
- Maximum light-oil pressure switch to stop the burner in case of the light-oil pressure on the return is higher then the set point value;
- Safety air pressure switch to stop the burner in lock-out (by stopping the pump motor) in case of failed or anomalous fan operation;
- Dedicated motor for the activation of the light-oil pump;
- Set up for the additional specific kit that transforms burner operation as modulating i.e. the modulating kit allows to supply any power between the minimun and the maximum value based on instantaneous loading request.

**CONFORMING TO:**

- CE rules;
- 2014/30/UE Directive E.M.C.;
- 2014/35/UE Directive L.V.;
- 2006/42/CE - 2006/42/EG - 2006/42/EC Directive M.D.;
- Directive PED 2014/68/UE (ART.4,PAR.3);
- Reference rules: EN267 (liquid fuel) - EN746-2 (industrial thermoprocessing equipment).

**STANDARD EQUIPMENT**

- Flexible hoses for connection;
- Line filter;
- Isomart gasket;
- Nozzle;
- Flange with insulating gasket;
- Burner nameplate;
- Warranty;
- Instruction handbook for installation, use and maintenance.

**OPTIONAL**

- Power modulating kits for temperatures;
- Power modulating kits for pressures;
- Temperature probe 0°C-400°C (PT 100 a 0° C);
- Temperature probe 0°C-350°C (J probe);
- Temperature probe 0°C-1200°C (K probe);
- Pressure probe 0-3 bar, 0-6 bar. 0-16 bar, 0-20 bar, 0-30 bar;
- Noise protection.