

Erdung nach örtlichen Vorschriften
 Mise à la terre conformément au réseau local
 Messa a terra in conformità alla rete locale
 Earthing in accordance with local regulation
 Earthing in accordance with local regulation
 Erdung nach örtlichen Vorschriften

Einspeisung
 Alimentation électrique
 Alimentazione elettrica
 Elektrische voeding
 Power supply

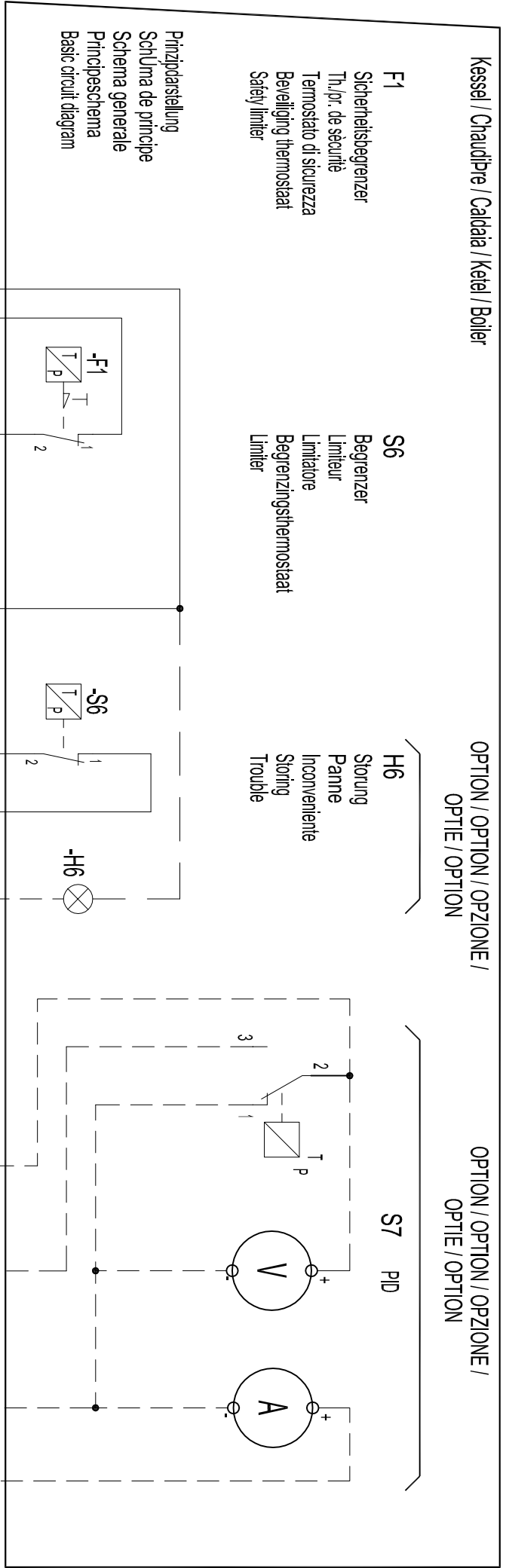

Prinzipdarstellung
 Schéma de principe
 Schema generale
 Principeschema
 Basic circuit diagram

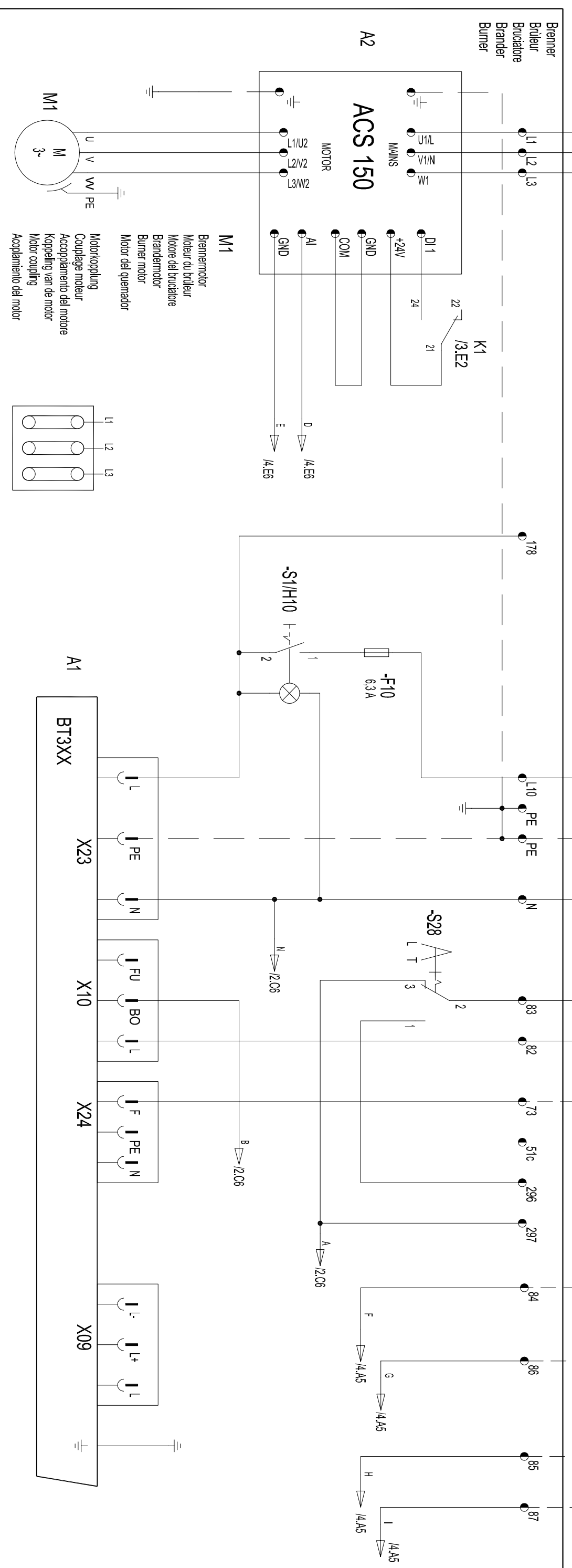

Brenner
Brûleur
Bruciatore
Brander
Burner

BT 3XX

A1

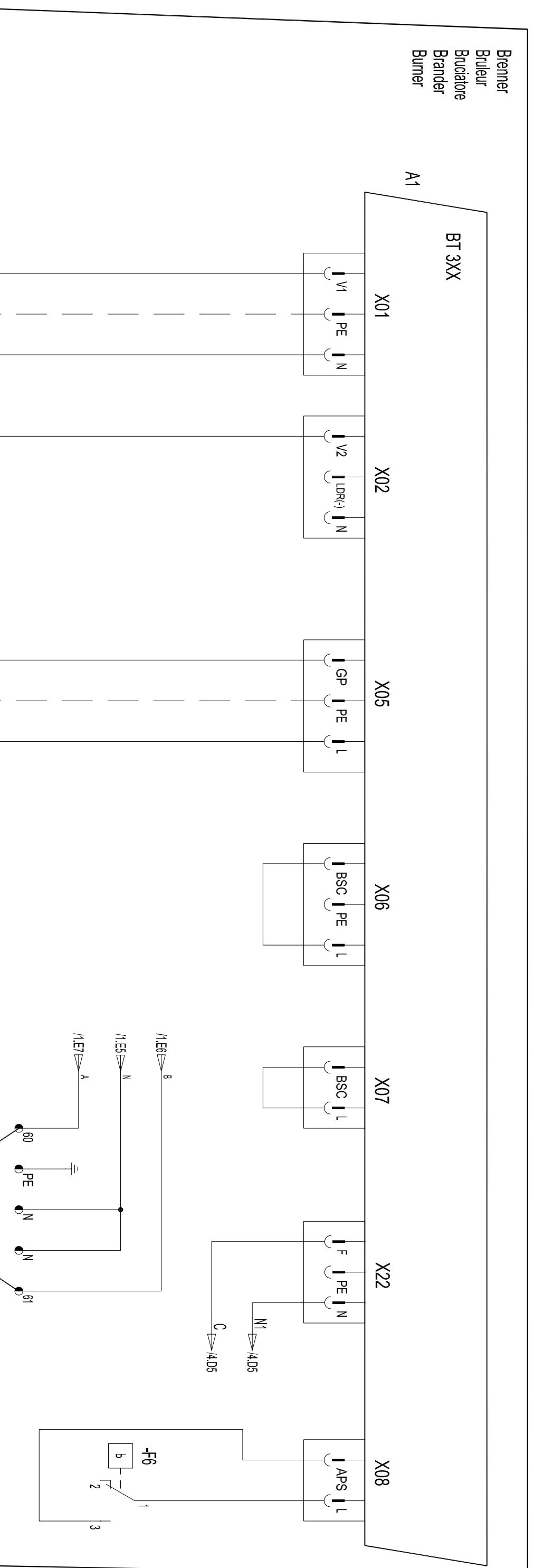

Gasramppe
Ramppe gaz
Rampa gas
Gasverdeelbuis
Gas train

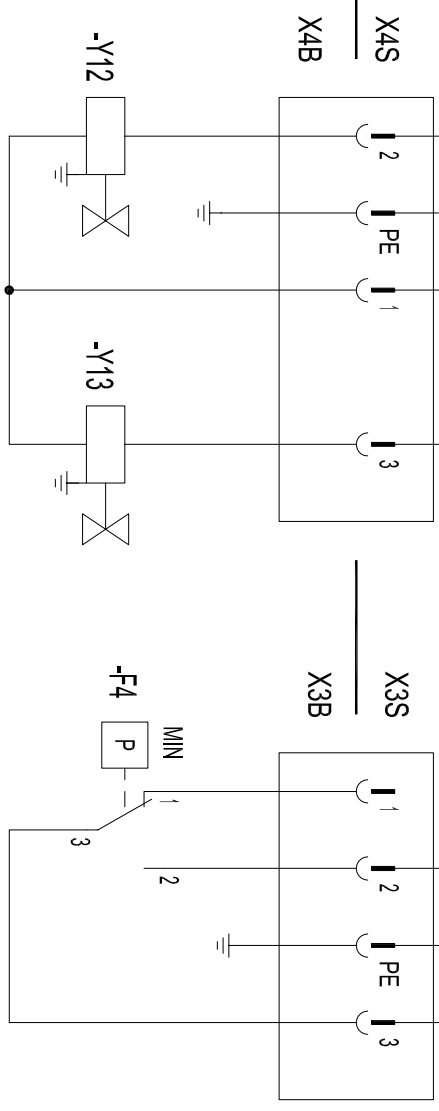

Brenner
Bruleur
Bruciatore
Brander
Burner

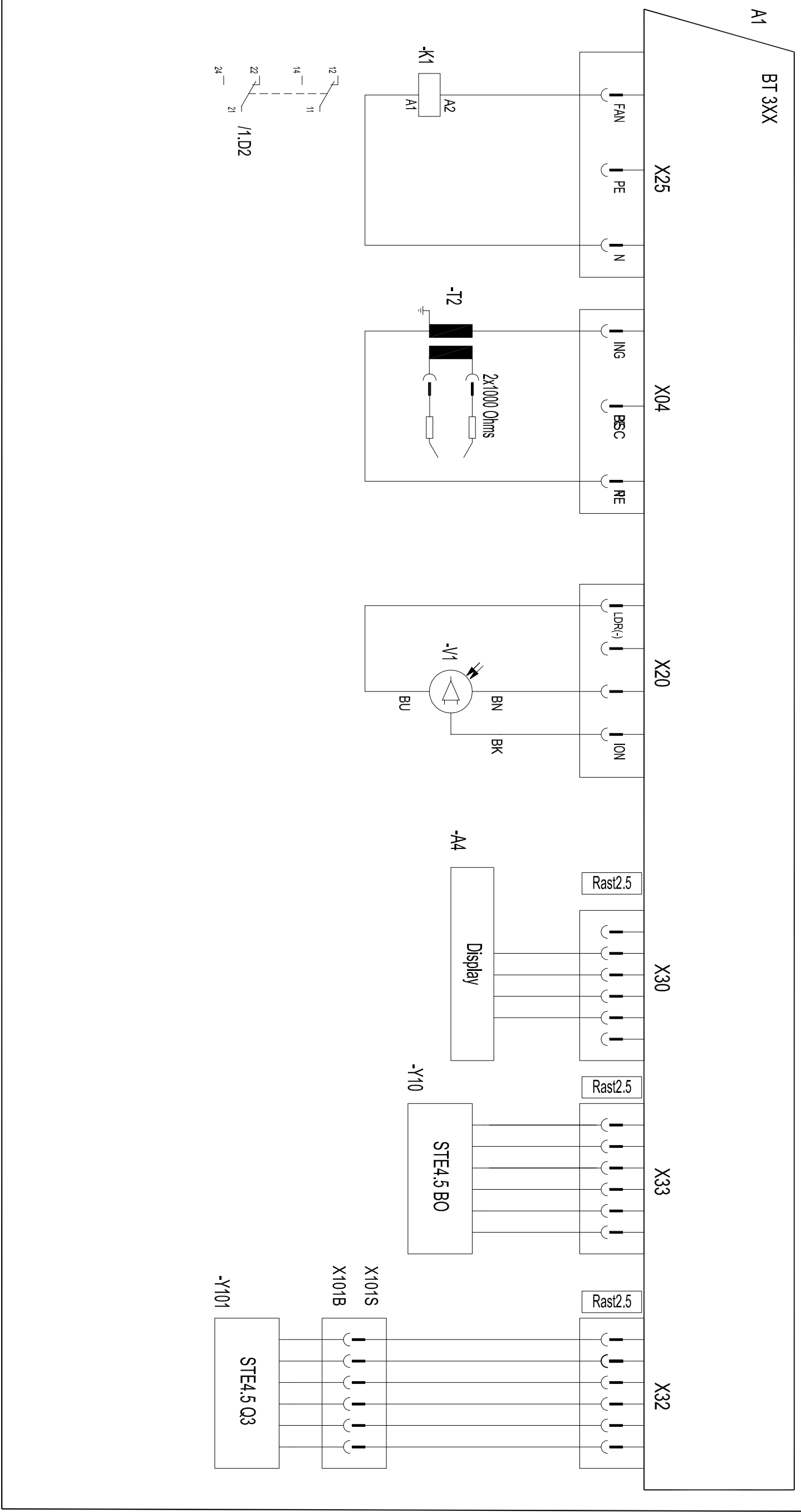

Brenner
Bruleur
Bruciatore
Brander
Burner

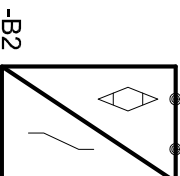
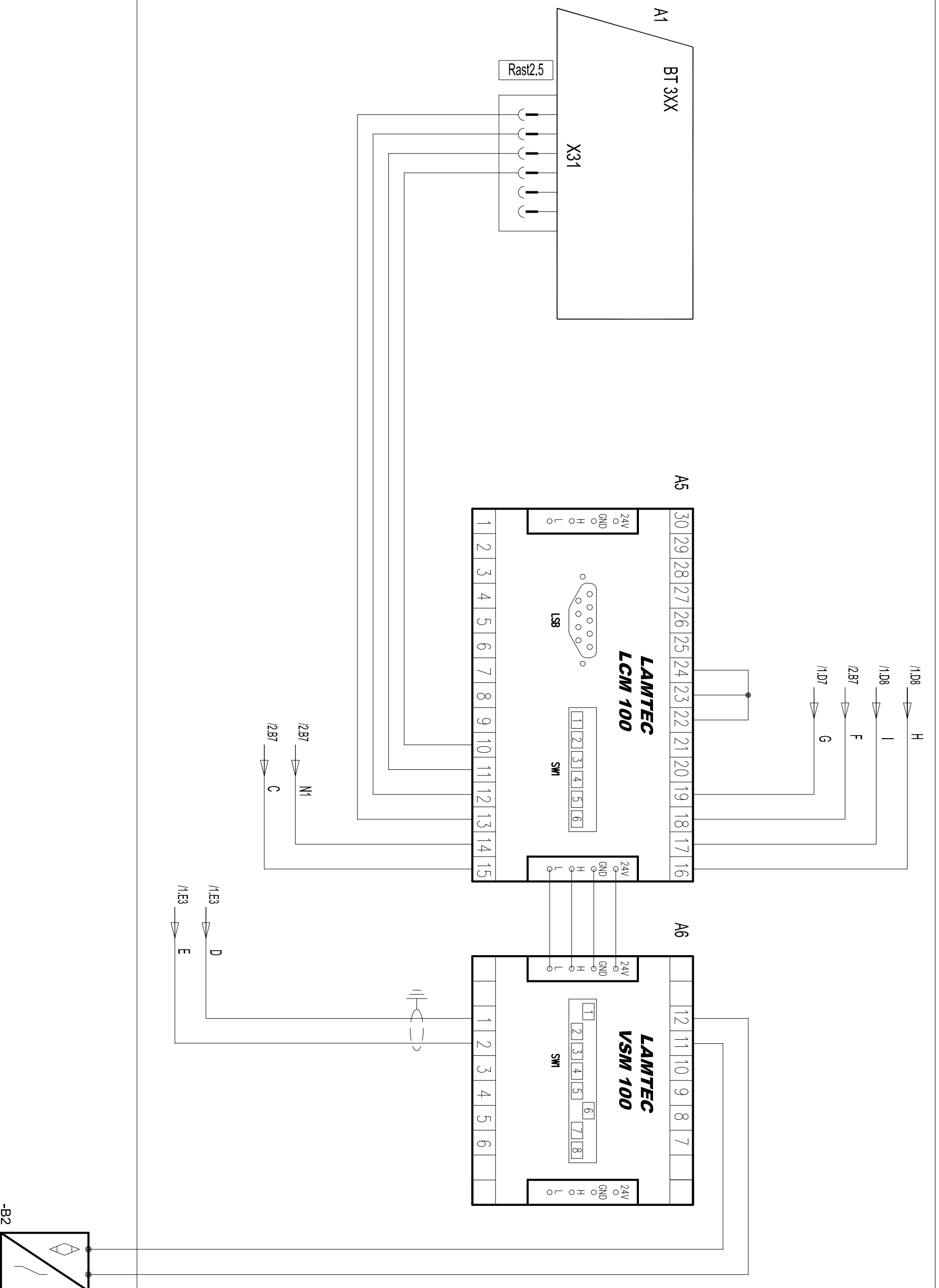

	"DE"	"FR"	"IT"	"NL"	"EN"
A1	Feuerungsautomat	Coffret de contrôle	Programmatore di comando	Bedienings en veiligheidskoffer	Control and safety unit
A2	Frequenzumrichter	Convertisseur de fréquence	Convertitore di frequenza	Frequentie-omvormer	Frequency converter
A4	Display	Afficheur	Visualizzatore	Uitlezing	Display
A5	Galvanische Trennung Gerät	Dispositif d'isolation galvanique	Modulo di isolamento galvanico	Galvanische scheiding apparaat	Galvanic isolation device
A6	Modul VSM	Module VSM	Modulo VSM	VSM module	VSM module
V1	Flammenwächter	Cellule	Rivelatore di fiamma	Fotocel	Cell
B2	Namur Geschwindigkeitssensor	Capteur de vitesse Namur	Sensore velocità Namur	Namur snelheidsensor	Namur speed sensor
F4	Gasdruckwächter min.	Manostat gaz mini	Pressostato gas min.	Gaspressostaat min.	Air pressure switch
F6	Luftdruckwächter	Manostat d'air	Pressostato aria	Luchtpressostaat	Min. gas pressure switch
F10	Sicherung	Fusible	Fusibile	Zekering	Control fuse
F12	Wärmeschutz M1	Protection thermique M1	Protezione termica M1	Thermische bescherming M1	Thermal protection M1
K1	Relais	Relais	Relè	Relais	Relay
M1	Brennmotor	Moteur du brûleur	Motore del bruciatore	Brandemotor	Burner motor
S1/H10	Ein/Aus	Marche/arrêt	Acceso/spento	Aan/Uit	ON/OFF
S28	Inter-Fernsteuerung / Vor-Ort	Inter. Télécommande/local	Inter. Telecomandolocale	Schakelaar Afstandsbediening/lokaal	Local/remote control inter.
T2	Zündratio	Transformateur d'allumage	Trasformatore d'accensione	Ontstekingstransformator	Ignition transformer
Y10	Luftklappen-Stellantrieb	Servomoteur air	Servomotore aria	Servomotor lucht	Air damper motor
Y101	Gasklappen-Stellantrieb	Servomoteur gaz	Servomotore gas	Servomotor gas	Gas damper motor
Y12	Gasventil gassseitig	Vanne gaz de sécurité	Valvola sicurezza gas	Veiligheidsventiel gas	Safety gas valve
Y13	Gasventil brennseitig	Vanne gaz principale	Valvola principale gas	Hoofdafsluiter gas	Gas valve burner side
296/297	Ein/Aus ferngesteuert	Marche/arrêt par télécommande	Acceso/spento con telecomando	Aan/Uit met afstandsbesturing	ON/OFF by remote control

F

E

D

C

B

A

Am /
ECN: RB15NP011

Date: 24-06-2015

Visa:

Art. N°:

420110169700

N° de schéma: VG6.1600 MV/TTC - VG6.2100 MV/TTC

Page: 5 / 6

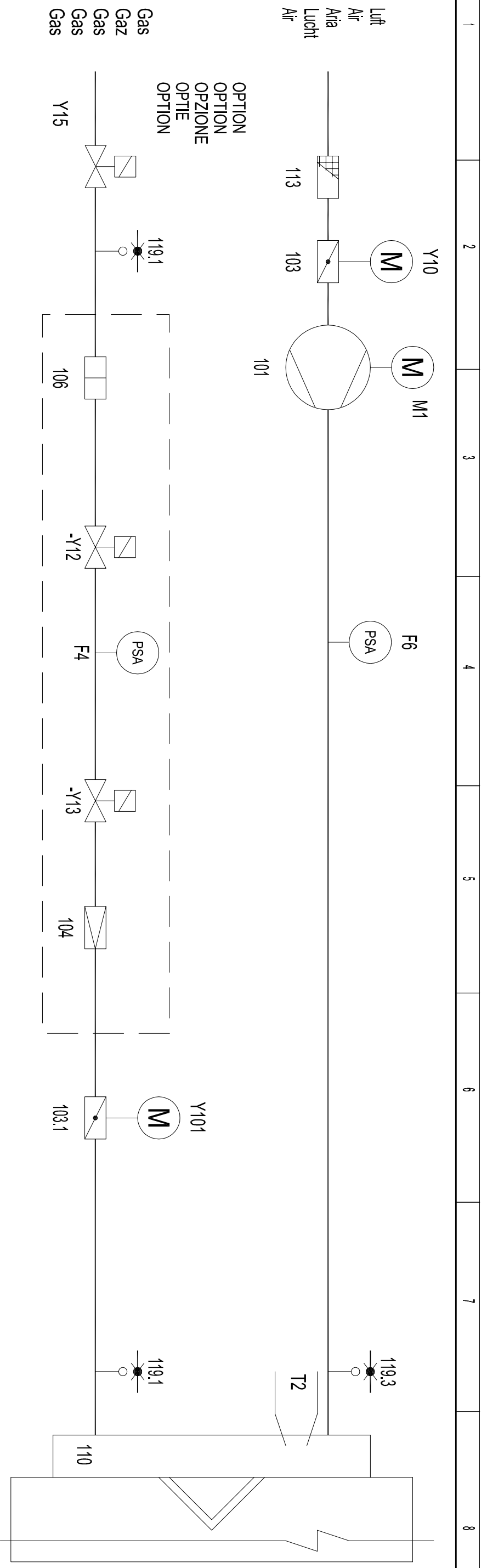

F4	Gasdruckwaechter min.	Manostat gaz mini	Pressostato gas min.	Gaspressostat min.	Min. gas pressure switch
F6	Luftdruckwaechter	Manostat d'air	Pressostato aria	Luchtpressostat	Air pressure switch
M1	Brennmotor	Moteur du bruleur	Motore del bruciatore	Brandemotor	Burner motor
T2	Zuendtrafo	Transformateur d'allumage	Trasformatore d'accensione	Onstekingstransformator	Ignition transformer
Y10	Luftklappen-Stellantrieb	Servomotor air	Servomotore aria	Servomotor lucht	Air damper motor
Y101	Gasklappen-Stellantrieb	Servomotor gaz	Servomotore gas	Servomotor gas	Gas damper motor
Y12	Gasventil gassseitig	Vanne gaz de securite	Valvola sicurezza gas	Veiligheidsventiel gas	Safety gas valve
Y13	Gasventil brennseitig	Vanne gaz principale	Valvola principale gas	Hoofdsuiker gas	Gas valve burner side
Y15	Schutzventil (Bauseits)	Vanne de protection (non fournie)	Valvola di protezione (non fornita)	Beschermingsventiel (niet geleverd)	Protective valve (not provided)
101	Ventilator	Ventilateur	Ventilatore	Ventilator	Blower
103	Luftklappe	Volet d'air	Serranda aria	Luchtklep	Air flap
103.1	Gasklappe	Volet de gaz	Serranda gas	Gasklep	Gas flap
104	Druckregler	Regulateur de pression	Regolatore della pressione	Drukregelaar	Pressure regulator
106	Filter	Filter	Fltro	Filter	Filter
108	Handventil	Vanne manuelle	Valvola manuale	Handventiel	Manual valve
110	Gasinjektor	Injecteur gaz	Ugello gas	Gasinjector	Gas injector
113	Ansauggitter	Gille d'aspiration	Scatola dell'aria	Luchthuis	Air box protection
119.1	Messnippel Gas	Prise pression gaz	Presza pressione gas	Meesnippel Gas	Gas pressure take-off
119.3	Messnippel Luft	Prise pression air	Presza pressione aria	Meesnippel Lucht	Air pressure take-off