

Erdung nach örtlichen Vorschriften  
 Mise à la terre conformément au réseau local  
 Messa a terra in conformità alla rete locale  
 Aarding in overeenstemming met het plaatselijk net  
 Earthing in accordance with local regulation

Einspeisung  
 Alimentation électrique  
 Alimentazione elettrica  
 Elektrische voeding  
 Power supply

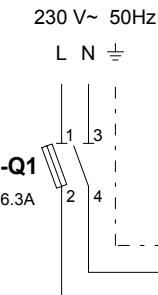

Kessel / Chaudière / Caldaia / Ketel / Boiler

Optionen / Options / Opzioni / Opties / Options

**F1**  
 Sicherheitsbegrenzer  
 Th./pr. de sécurité  
 Termostato di sicurezza  
 Beveiliging thermostaat  
 Safety limiter

**S6**  
 Begrenzer  
 Limiteur  
 Limitatore  
 Begrenzingsthermostaat  
 Limiter

**H6**  
 Störung  
 Panne / Défaut  
 Inconveniente  
 Storing  
 Trouble

**P4**  
 Betriebsstundenzähler  
 Compteur horaire  
 Contaore  
 Uurteller  
 Running hours meter

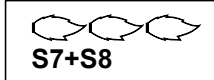
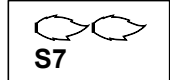

**S7**  
 Stufe 1/2  
 Allure 1/2  
 Stadio 1/2  
 Trap 1/2  
 Stage 1/2

**S8**  
 Stufe 2/3  
 Allure 2/3  
 Stadio 2/3  
 Trap 2/3  
 Stage 2/3

Prinzipdarstellung  
 Schéma de principe  
 Schema generale  
 Principeschema  
 Basic circuit diagram  
 Prinzipdarstellung

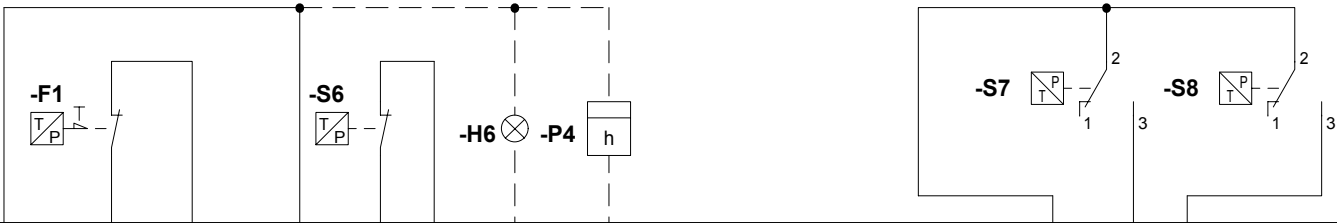

Brenner  
 Brûleur  
 Bruciatore  
 Brander  
 Burner

**TCH 3xx**

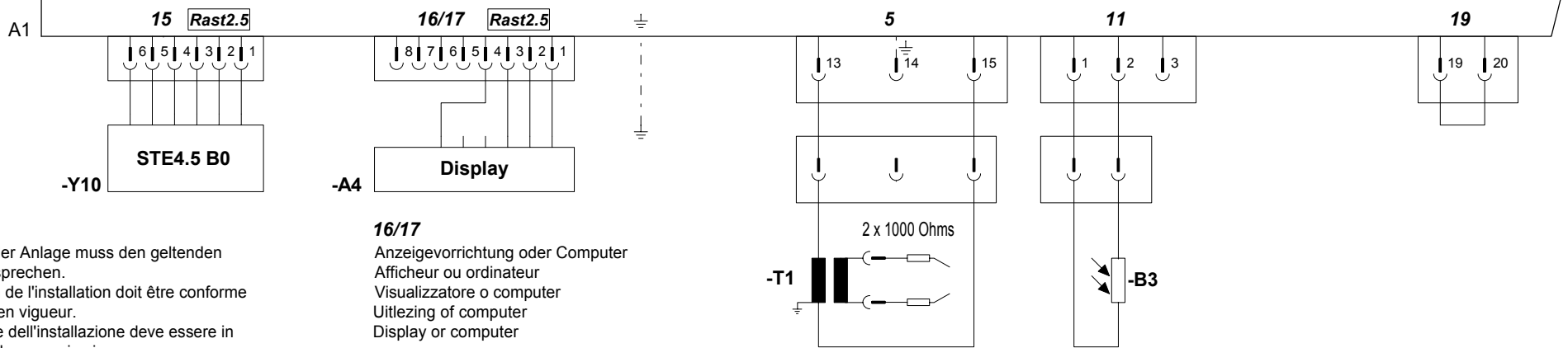

Der Schutz der Anlage muss den geltenden Normen entsprechen.  
 La protection de l'installation doit être conforme aux normes en vigueur.  
 La protezione dell'installazione deve essere in conformità alle norme in vigore.  
 Bescherming van de installatie moet in overeenstemming volgens de wettelijk geldende normen.  
 Protection of the installation must comply with the actual norms.

**16/17**  
 Anzeigevorrichtung oder Computer  
 Afficheur ou ordinateur  
 Visualizzatore o computer  
 Uitlezing of computer  
 Display or computer

A  
B  
C  
D  
E  
F

**Optionen / Options / Opzioni / Opties / Options**

<b>20</b> Reset Déverrouillage Sblocco Reset Reset	<b>21</b> Störung Panne / Défaut Inconveniente Storing Trouble	<b>6</b> Ständige Stromversorgung Alimentazione permanente Alimentazione permanente Permanente stroomvoorziening Permanent power supply
---	---	--

Brenner  
Brûleur  
Bruciatore  
Brander  
Burner

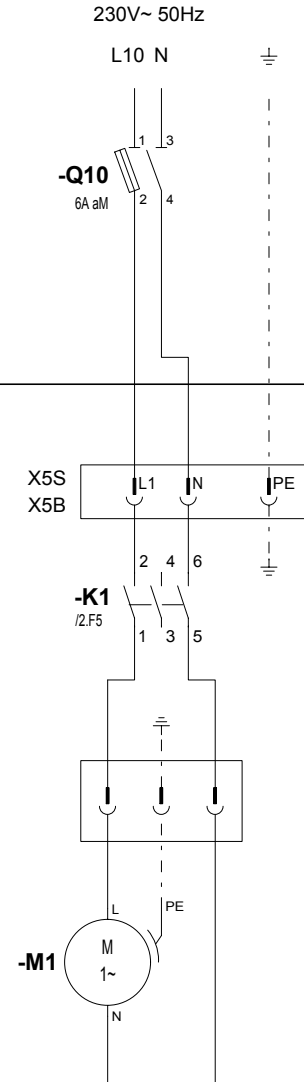
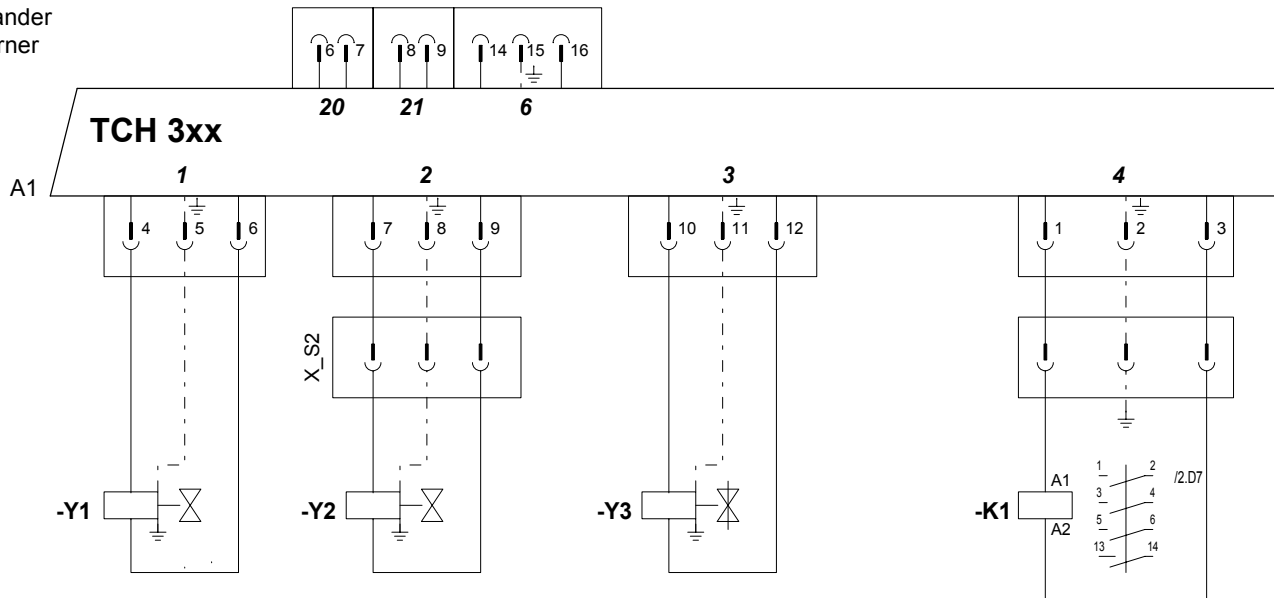

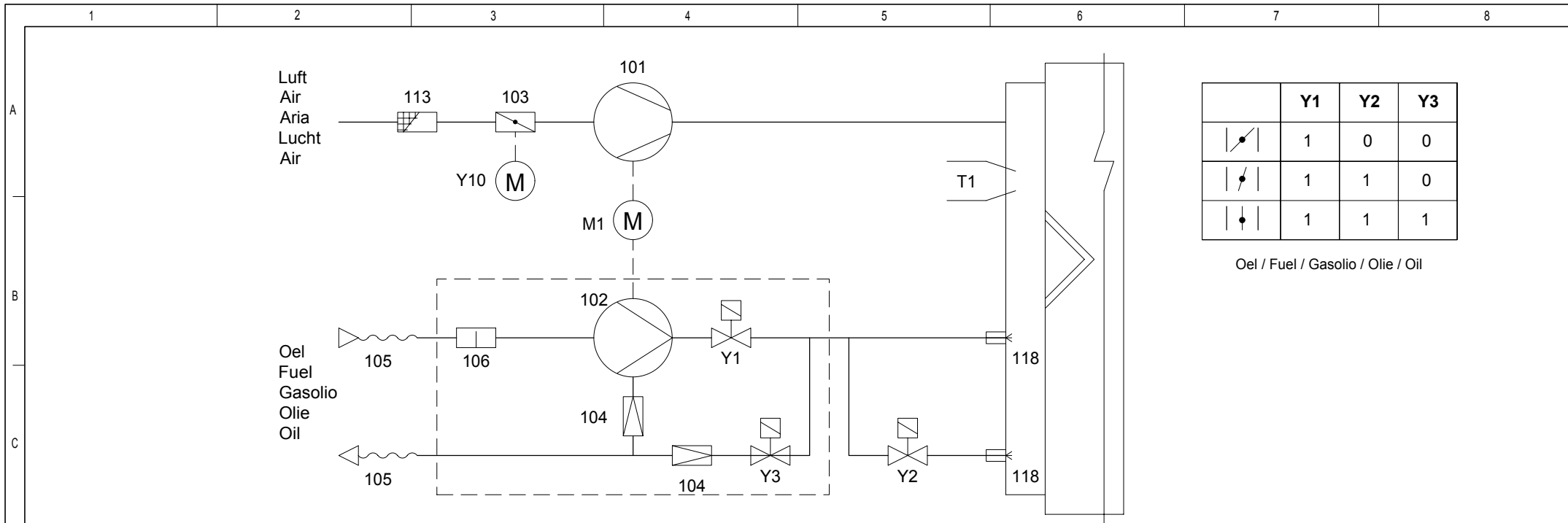

	Y1	Y2	Y3
	1	0	0
	1	1	0
	1	1	1

Oel / Fuel / Gasolio / Olive / Oil

<b>A1</b>	Feuerungsautomat	Coffret de contrôle	Programmatore di comando	Bedienings en veiligheidskoffer	Control and safety unit
<b>A4</b>	Display	Afficheur	Visualizzatore	Uitlezing	Display
<b>B3</b>	Flammenwächter	Cellule	Rivelatore di fiamma	Fotocel	Cell
<b>K1</b>	Kontaktschalter des Ventilators	Contacteur du ventilateur	Contattore del ventilatore	Contacteur van ventilator	Fan unit contactor
<b>M1</b>	Brennermotor	Moteur du brûleur	Motore del bruciatore	Brandermotor	Burner motor
<b>T1</b>	Zündtrafo	Transformateur d'allumage	Trasformatore d'accensione	Ontstekingstransformator	Ignition transformer
<b>Y1</b>	Oelventil Stufe 1	Vanne fuel 1° allure	Valvola gasolio stadio 1	Olieventiel trap 1	Oil valve stage 1
<b>Y2</b>	Oelventil Stufe 2	Vanne fuel 2° allure	Valvola gasolio stadio 2	Olieventiel trap 2	Oil valve stage 2
<b>Y3</b>	Oelventil Stufe 3	Vanne fuel 3° allure	Valvola gasolio stadio 3	Olieventiel trap 3	Oil valve stage 3
<b>Y10</b>	Stellantrieb	Servomoteur	Servomotore	Servomotor	Servomotor
<b>101</b>	Ventilator	Ventilateur	Ventilatore	Ventilator	Blower
<b>102</b>	Pumpe	Pompe	Pompa	Pomp	Pump
<b>103</b>	Luftklappe	Volet d'air	Serranda aria	Luchtklep	Air flap
<b>104</b>	Druckregler	Régulateur de pression	Regolatore della pressione	Drukregelaar	Pressure regulator
<b>105</b>	Schlauch	Flexible	Tubi flessibili	Soepele leiding	Hose
<b>106</b>	Filter	Filtre	Filtro	Filter	Filter
<b>113</b>	Ansauggitter	Grille d'aspiration	Scatola dell'aria	Luchthuis	Air box protection
<b>118</b>	Düse	Gicleur	Ugello	Sproier	Nozzle