

**LP30**

**High Integrity, Self-monitoring Low Level Alarm Probe**  
**Installation and Maintenance Instructions**

---

---

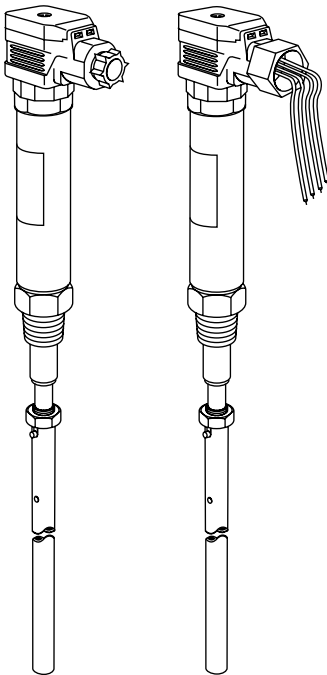

- 1. Safety information*
- 2. General product information*
- 3. Installation*
- 4. Wiring*
- 5. Probe clearance test procedure*
- 6. Maintenance*
- 7. Spare parts*



---

# 1. Safety information

---

Your attention is drawn to any National or local regulations.

The product is designed and constructed to withstand the forces encountered during normal use. Use of the product for any other purpose, or failure to install the product in accordance with these Installation and Maintenance Instructions, could cause damage to the product and may cause injury or fatality to personnel.

The LP30 level probe and LC3050 level controller comply with the requirements of the European Pressure Equipment Directive 97/23/EC and carry the CE mark. They are classed as Safety Accessories and therefore fall within Category 4 of the Directive.

## Warning

If this product is not used in the manner specified by this IMI, then the protection provided may be impaired.

### 1.1 Intended use

- i) Check that the product is suitable for use with the intended fluid.
- ii) Check material suitability, pressure and temperature and their maximum and minimum values. If the maximum operating limits of the product are lower than those of the system in which it is being fitted, or if malfunction of the product could result in a dangerous overpressure or overtemperature occurrence, ensure a safety device is included in the system to prevent such over-limit situations.
- iii) Determine the correct installation situation and direction of fluid flow.
- iv) Spirax Sarco products are not intended to withstand external stresses that may be induced by any system to which they are fitted. It is the responsibility of the installer to consider these stresses and take adequate precautions to minimise them.
- v) Remove protection covers from all connections and protective film from all name-plates, where appropriate, before installation on steam or other high temperature applications.

Safe operation of these products can only be guaranteed if they are properly installed, commissioned, used and maintained by qualified personnel (see Section 1.11) in compliance with the operating instructions. General installation and safety instructions for pipeline and plant construction, as well as the proper use of tools and safety equipment must also be complied with.

### 1.2 Access

Ensure safe access and if necessary a safe working platform (suitably guarded) before attempting to work on the product. Arrange suitable lifting gear if required.

### 1.3 Lighting

Ensure adequate lighting, particularly where detailed or intricate work is required.

### 1.4 Hazardous liquids or gases in the pipeline

Consider what is in the pipeline or what may have been in the pipeline at some previous time. Consider: flammable materials, substances hazardous to health, extremes of temperature.

---

## 1.5 Hazardous environment around the product

Consider: explosion risk areas, lack of oxygen (e.g. tanks, pits), dangerous gases, extremes of temperature, hot surfaces, fire hazard (e.g. during welding), excessive noise, moving machinery.

## 1.6 The system

Consider the effect on the complete system of the work proposed. Will any proposed action (e.g. closing isolation valves, electrical isolation) put any other part of the system or any personnel at risk?

Dangers might include isolation of vents or protective devices or the rendering ineffective of controls or alarms. Ensure isolation valves are turned on and off in a gradual way to avoid system shocks.

## 1.7 Pressure systems

Ensure that any pressure is isolated and safely vented to atmospheric pressure. Consider double isolation (double block and bleed) and the locking or labelling of closed valves. Do not assume that the system has depressurised even when the pressure gauge indicates zero.

## 1.8 Temperature

Allow time for temperature to normalise after isolation to avoid danger of burns.

## 1.9 Tools and consumables

Before starting work ensure that you have suitable tools and/or consumables available. Use only genuine Spirax Sarco replacement parts.

## 1.10 Protective clothing

Consider whether you and/or others in the vicinity require any protective clothing to protect against the hazards of, for example, chemicals, high/low temperature, radiation, noise, falling objects, and dangers to eyes and face.

## 1.11 Permits to work

All work must be carried out or be supervised by a suitably competent person. Installation and operating personnel should be trained in the correct use of the product according to the Installation and Maintenance Instructions.

Where a formal 'permit to work' system is in force it must be complied with. Where there is no such system, it is recommended that a responsible person should know what work is going on and, where necessary, arrange to have an assistant whose primary responsibility is safety.

Post 'warning notices' if necessary.

## 1.12 Handling

Manual handling of large and/or heavy products may present a risk of injury. Lifting, pushing, pulling, carrying or supporting a load by bodily force can cause injury particularly to the back. You are advised to assess the risks taking into account the task, the individual, the load and the working environment and use the appropriate handling method depending on the circumstances of the work being done.

## 1.13 Residual hazards

In normal use the external surface of the product may be very hot.

Many products are not self-draining. Take due care when dismantling or removing the product from an installation.

---

## 1.14 Freezing

Provision must be made to protect products which are not self-draining against frost damage in environments where they may be exposed to temperatures below freezing point.

## 1.15 Safety information - Product specific for level control and level limiting/alarm products in steam boilers

Products/systems must be selected, installed, operated, and tested in accordance with:

- Local or National standards and regulations.
- Guidance Notes, (Health and Safety Executive BG01 and INDG436 in the UK).
- The requirements of Approvals Authorities.
- Boiler Insurance Bodies.
- Boiler manufacturer's specifications.

The boiler must be depressurised and vented to atmosphere before installation of the probe.

Two independent low water limiting/alarm systems must be installed on steam boilers. Level probes must be installed in separate protection tubes/chambers, with sufficient clearance between the tips, and earth.

Each probe must be connected to an independent controller. The alarm relays must isolate the boiler heat supply at low alarm status.

A high water alarm may be part of the water level control, or a separate system. An independent high water alarm system must be fitted if it is considered a safety requirement. In this case, the relays must simultaneously isolate the feedwater supply and the boiler heat supply at high alarm status. All boiler water limiters/alarms require regular functional testing.

Under certain circumstances the water level in a boiler can be different to that shown in the gauge glass.

Separate literature is available from Spirax Sarco on this subject.

Do not install the probe outdoors without additional weather protection.

Drain / vent holes must be kept clear - do not cover.

A suitable water treatment regime must be used to ensure continuous safe and correct operation of the control and limiter systems. Consult the above authorities and a competent water treatment company.

## 1.16 Disposal

Unless otherwise stated in the Installation and Maintenance Instructions, this product is recyclable and no ecological hazard is anticipated with its disposal providing due care is taken.

## 1.17 Returning products

Customers and stockists are reminded that under EC Health, Safety and Environment Law, when returning products to Spirax Sarco they must provide information on any hazards and the precautions to be taken due to contamination residues or mechanical damage which may present a health, safety or environmental risk. This information must be provided in writing including Health and Safety data sheets relating to any substances identified as hazardous or potentially hazardous.

## — 2. General product information —

### 2.1 General description

The Spirax Sarco LP30 probe is used with the Spirax Sarco LC3050 level controller to provide a high integrity, self-monitoring low level alarm signal, usually in a steam boiler. It consists of a probe body with a removable cable socket, and a separate screw-on probe tip. The tip is retained with a roll pin, and held in place with a lock-nut. Two level probes and controllers are normally installed on each boiler to provide two independent low alarms. In many countries this provides first low alarm and second low alarm. The probe is suitable for boiler pressures of up to 32 bar g (464 psi g).

### 2.2 Available tip lengths mm (inches)

500 (19.7), 1 000 (39.4) and 1 500 (59).

### 2.3 Pressure / temperature limits

Nominal pressure rating	PN40	
Maximum boiler pressure	32 bar g	(464 psi g)
Maximum operating temperature	239°C	(462°F)
Maximum ambient temperature	70°C	(158°F)
Designed for a maximum cold hydraulic test pressure of:	60 bar g	(870 psi g)

### 2.4 Technical data

Maximum probe cable length	50 metres	(164 ft)
Cable socket protection rating	IP65	

### 2.5 How the LP30 works

The probe has a level sensing tip (probe tip) and a comparator tip. The earth return path is via the body connection.

Under normal operating conditions, the probe tip is immersed, and the resistance to earth is low. When the water level drops below the probe tip the resistance to earth becomes high, causing the controller to give a low level alarm signal.

The comparator tip compensates for any leakage to earth caused by scale, dirt, or internal moisture, ensuring a low water alarm signal even under adverse conditions.

A DIN 43650 cable socket is supplied with each unit and is provided with a Pg 11 cable gland, or, for the UL/FM version, a ½" NPT conduit thread adaptor with four flying leads.

**WARNING: It is essential that the probe tip does not touch any part of the boiler. Standards require that the tip is at least 14 mm (½") from the protection tube, and this must be checked when the probe is installed. See Section 5, 'Probe clearance test procedure'.**

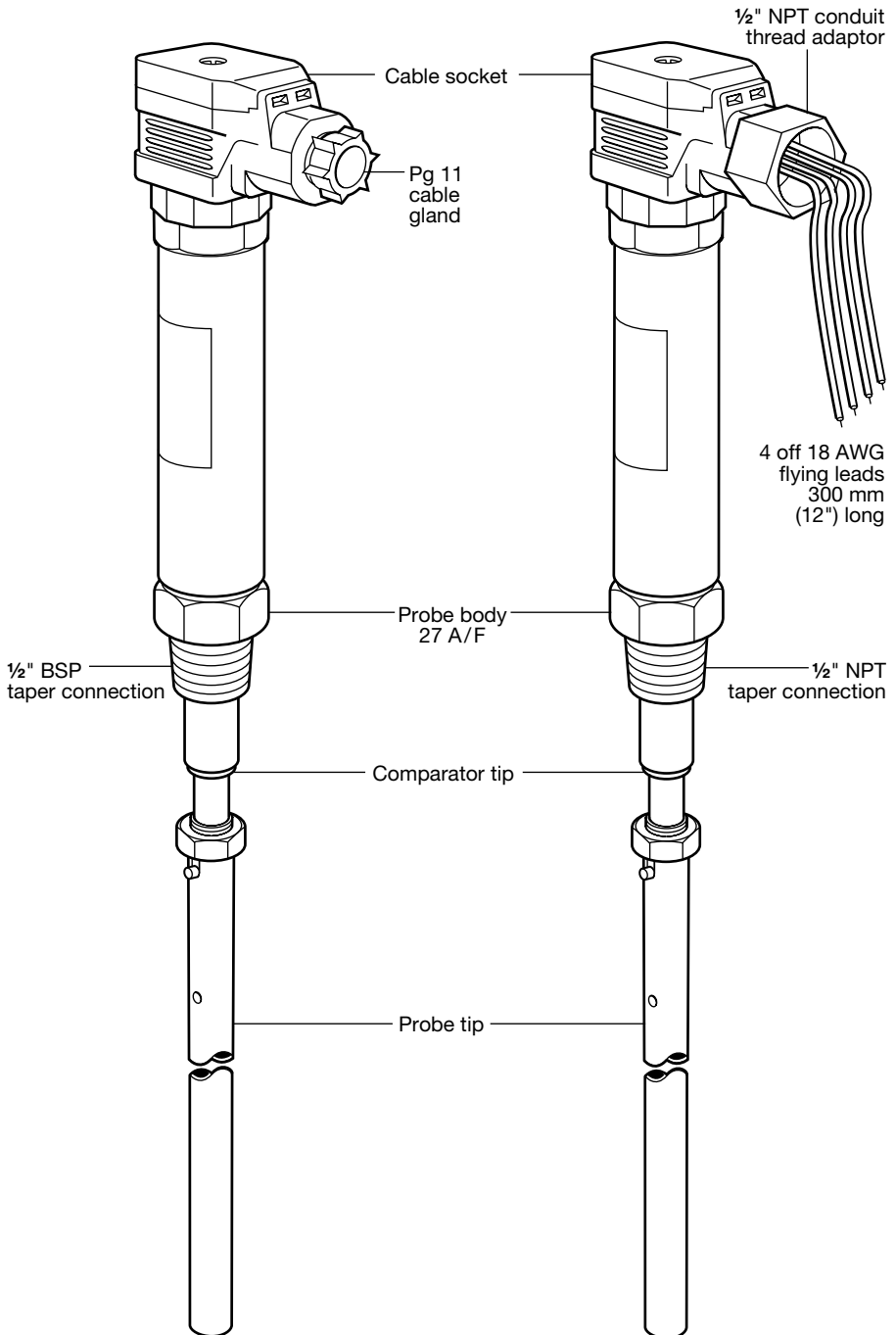

**Fig. 1**  
LP30 Standard version

**Fig. 2**  
LP30 UL version

# 3. Installation

**Before proceeding with any installation or maintenance read Section 1, 'Safety information'.**

When the probe is to be installed in the boiler, ensure it is positioned at least 1 metre (39") from any safety valve or steam take-off, as increased localised water levels may occur.

## 3.1 Deciding on the low alarm levels

In most shell boilers the water will 'swell' when it is firing, such that the actual water level will be higher than the level shown in the gauge glass. In practice this can be up to 50 mm (2") in very large boilers reducing to about 10 mm ( $\frac{3}{8}$ ") in smaller ones. We recommend, therefore, that the second low level alarm should be well above the bottom of the gauge glass when the boiler is cold, as this will reduce when the boiler is firing. The first low level alarm may be 20 mm ( $\frac{3}{4}$ ") above second low level alarm (see Figure 3). Wherever possible the boiler manufacturer should be consulted for advice on the working and alarm water levels.

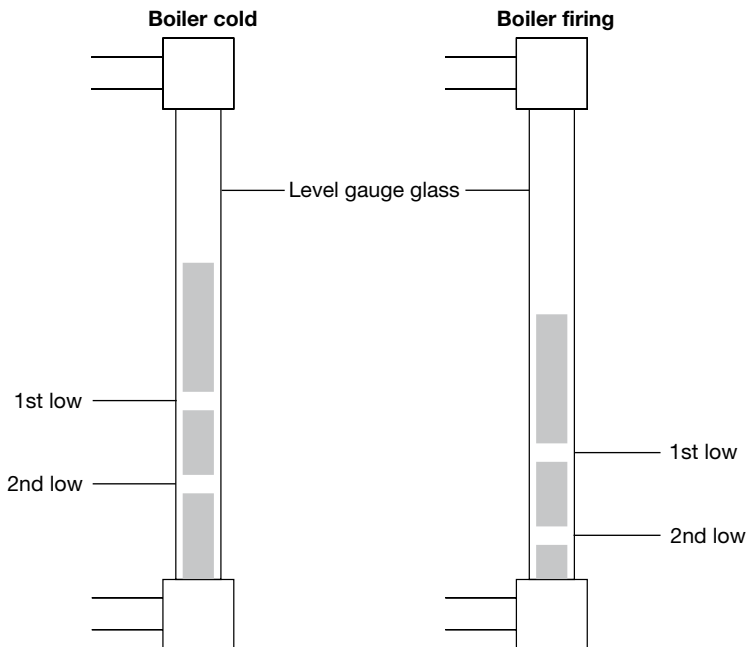

**Fig. 3 Typical low alarm levels**

## 3.2 Protection tube

The probe must be installed in a protection tube when used as a low level alarm in a steam boiler. The protection tube provides a relatively steady water level, shielding the probe from the turbulence in the boiler. Two separate protection tubes must be provided, one for the first low level alarm and one for the second low level alarm. A typical protection tube is shown in Figure 4. Dimensions and construction may be varied to suit the application, but a tube of at least 80 mm (3") diameter is recommended.

Flange lagging is recommended, particularly on larger boilers or boilers with a working pressure over 10 bar g (145 psi g). Do not lag the probe.

**Do not cover the vent or drain holes on the body.**

**Note:** When making flanged or screwed joints, ensure that excess jointing compound does not enter the boiler.



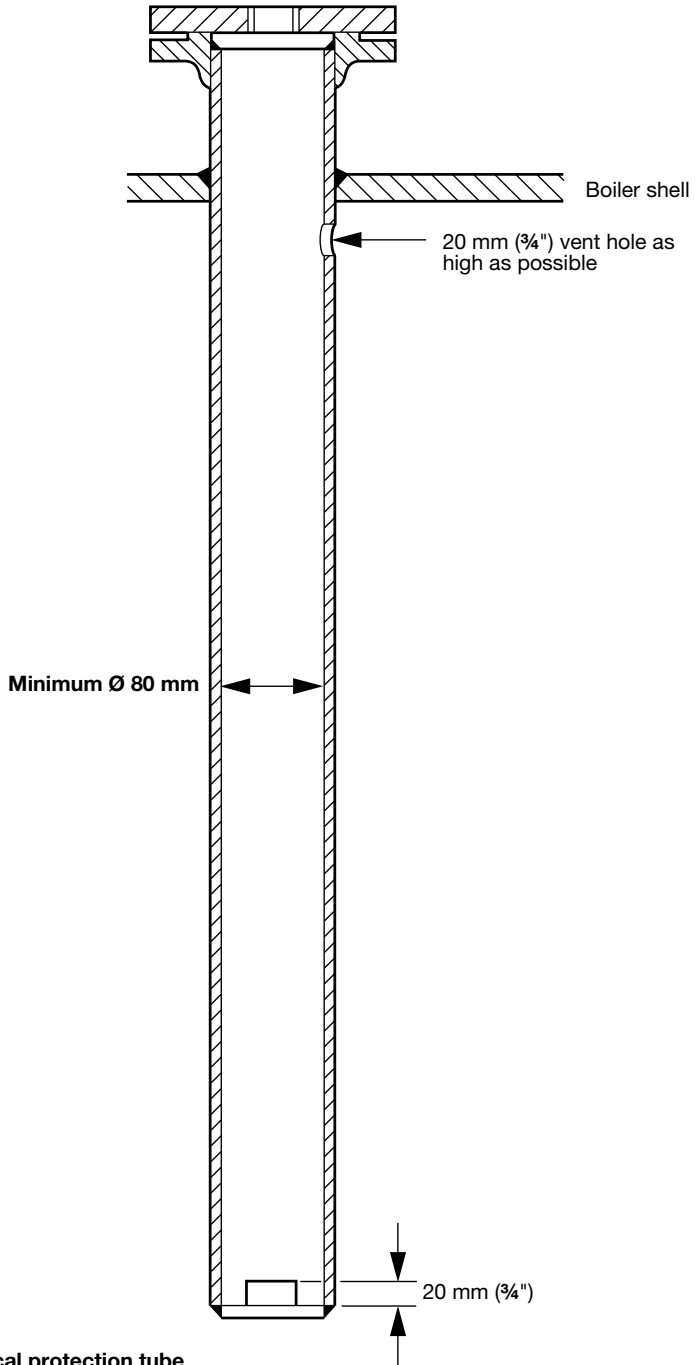

Fig. 4 Typical protection tube

---

### 3.3 Cutting the probe tip

The probe is normally installed vertically, but for probe tip lengths of up to 500 mm (20") it may be inclined by up to 45° from the vertical. The low alarm switching level is at the extreme end of the probe tip, which is cut to length to give the required alarm level.

#### **LP30 probe tips are retained by a thread, pin and lock-nut:**

- Earlier probes were retained by two pins only.
- A compatible tip is available to special order.

For existing installations, it is important to check which type of connection is used before cutting the probe tip to length.

#### **3.3.1 Procedure for cutting the tip:**

- Screw the lock-nut onto the probe fully, but do not tighten it at this stage.
- Use an M6 spanner on the flats of the probe tip connector to prevent it rotating.

**WARNING: If the threaded end of the connector is allowed to rotate in the probe body, the internal wiring will be damaged.**

- Screw the probe tip onto the probe until the hole in the probe lines up with the bottom of the slot in the probe tip (see Figure 5).
- Support the assembly and tap in the retaining pin until an equal length protrudes from each side of the probe tip.
- Tighten the lock-nut onto the probe tip (5-7 N m, 4-5 lbf ft).
- Ensure the boiler water is at the required low alarm level.
- Mark a line down the length of the probe tip using a water-soluble felt pen.
- Temporarily fit the probe and tip to the boiler (½" BSP taper for standard LP30 and ½" NPT for UL/FM versions), hand tight, without using PTFE tape.
- Remove the probe and note the point at which the ink is dissolved by the water.
- Use a fine hacksaw to cut the probe tip to this length (see Figure 6).
- De-burr tip.
- Carry out the probe clearance test procedure (see Section 5, 'Probe clearance test procedure') and record the results.

**Note:** A chart is provided for recording this data.

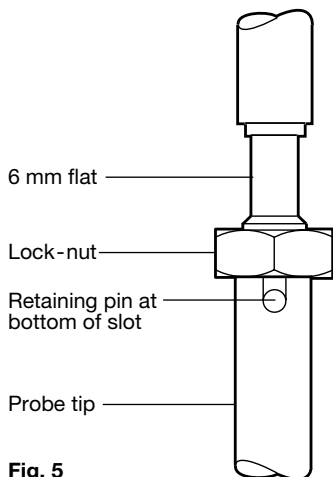

Fig. 5

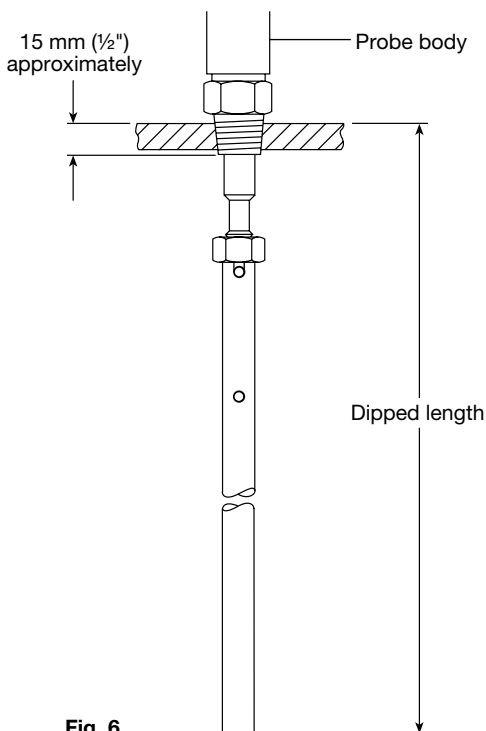

Fig. 6

### 3.3.2 Install the probe as follows:

- Ensure both male and female threads are in good condition.
- Use up to three turns (no more) of PTFE thread sealing tape on the probe thread.  
**WARNINGS: Do not use excessive tape. Do not use paste type jointing compound.**
- Fit and tighten the probe by hand initially.
- Use a suitable spanner to tighten the probe. Under no circumstances use a pipe wrench.
- Due to the nature of a taper/parallel joint it is not possible to recommend tightening torque figures.
- Do not overtighten - there should always be visible thread on the probe.
- **Note:** The probe thread will not 'bottom out' (i.e. probe body hexagon contacts the face of the female screwed connection), unless there is excessive wear or an out-of-tolerance female thread, in which case it will be necessary to replace or re-work the flange or connection.

### 3.3.3 Subsequent removal and refitting:

**WARNING: Ensure boiler or vessel is depressurised and vented to atmosphere before attempting to unscrew or remove the probe.**

- Always use the correct size spanner - not a pipe wrench.
- Inspect male and female threads for signs of damage, which may have occurred through overtightening, leading to torn threads or even localised cold welding (galling / picking up).
- If damage has occurred replace the probe.

## 4. Wiring

Refer to the relevant controller documentation/wiring diagram for full information, including screen connection details.

Cabling should be installed in accordance with BS 6739 - Instrumentation in Process Control Systems: Installation design and practice or local equivalent. For US and Canadian installations the probe must be wired in accordance with the National and Local Electrical code (NEC) or the Canadian Electrical code (CEC). Wiring should be carried out using 4 core, 1 mm<sup>2</sup> (18-16 AWG), high temperature screened cable, with a maximum length of 50 metres (165 ft). Pirelli FP 200 or Delta Crompton Firetuf OHLS are two suitable types for the standard LP30. For the UL/FM version, Class 1 screened cable with a suitable temperature rating (75°C/167°F minimum) must be used to connect the terminal box to the controller.

Ensure that sufficient cable length is provided to allow removal of the cable socket and to ensure that no strain is placed on the unit.

To unplug the cable socket, remove the central screw.

**Note: To provide environmental protection the probe is supplied with a gasket between the cable socket and the probe connector. To maintain environmental integrity, ensure the gasket is always present when reconnecting cable socket and that all contact surfaces are clean and undamaged.**

To gain access to the connector block within the cable socket, remove the central screw and withdraw the hinged cover.

**The connector block on the standard LP30 maybe rotated in 90° steps to facilitate wiring:**

- Remove the retaining screw and withdraw socket.
- Remove connector block and reposition as required.

**Note: It is not possible to rotate the connector block on the UL/FM version.**

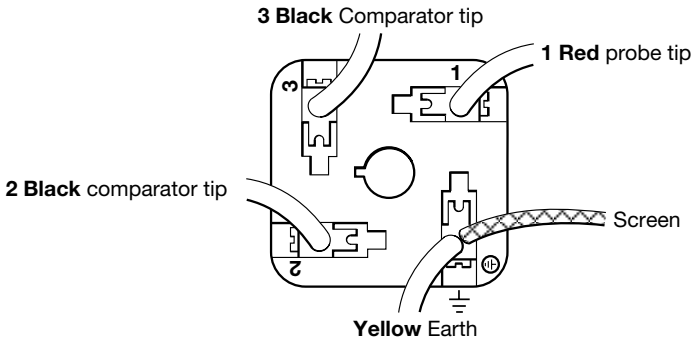

**Fig. 7 View of connector block removed from cable connector**

### UL / FM version

The socket is supplied with four 18 AWG, 300 mm (12") long colour coded flying leads. These are to be cut to length and connected to a suitable metal terminal box. A length of flexible metal conduit is required between the probe and the terminal box to provide environmental protection and easy electrical connection. The cable socket is provided with a ½" NPT conduit adaptor for this purpose.

### WARNING:

The flying leads supplied with the probe are rated to 221°F (105°C). This temperature rating must not be exceeded.

The flexible conduit and terminal box are not to incorporate any other control wiring as this may damage or reduce the performance of the product.

It is not possible to rotate the cable socket in 90° steps, as with the non-listed LP30. To do so may damage the internal wiring.

Ensure that any condensation which might build up in the conduit network is prevented from accumulating in the probe cable connector and terminal box.

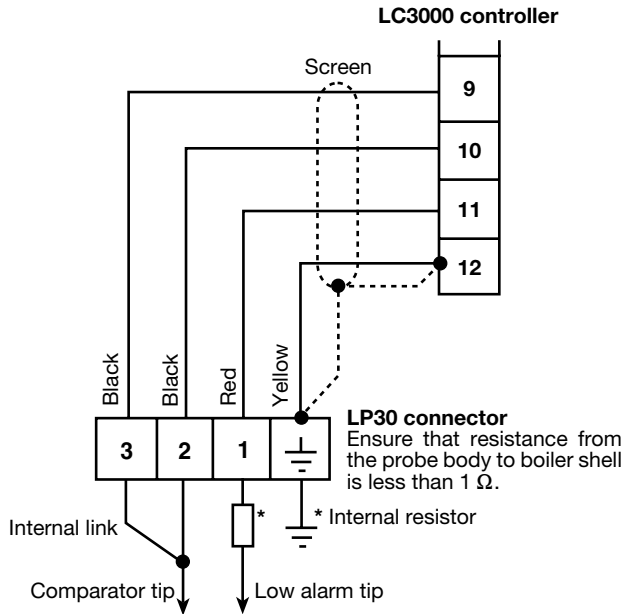

**Fig. 8 Standard version**

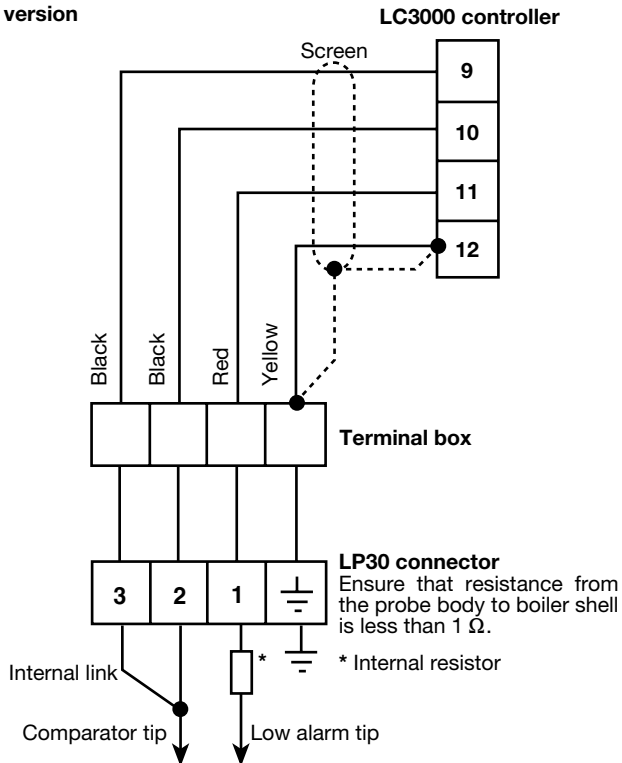

**Fig. 9 UL/FM version**

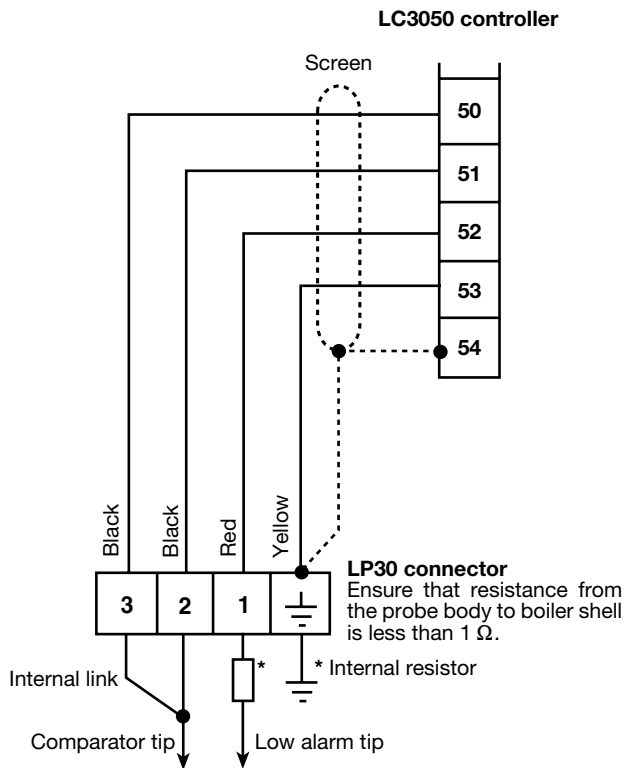

**Fig. 10 Standard version**

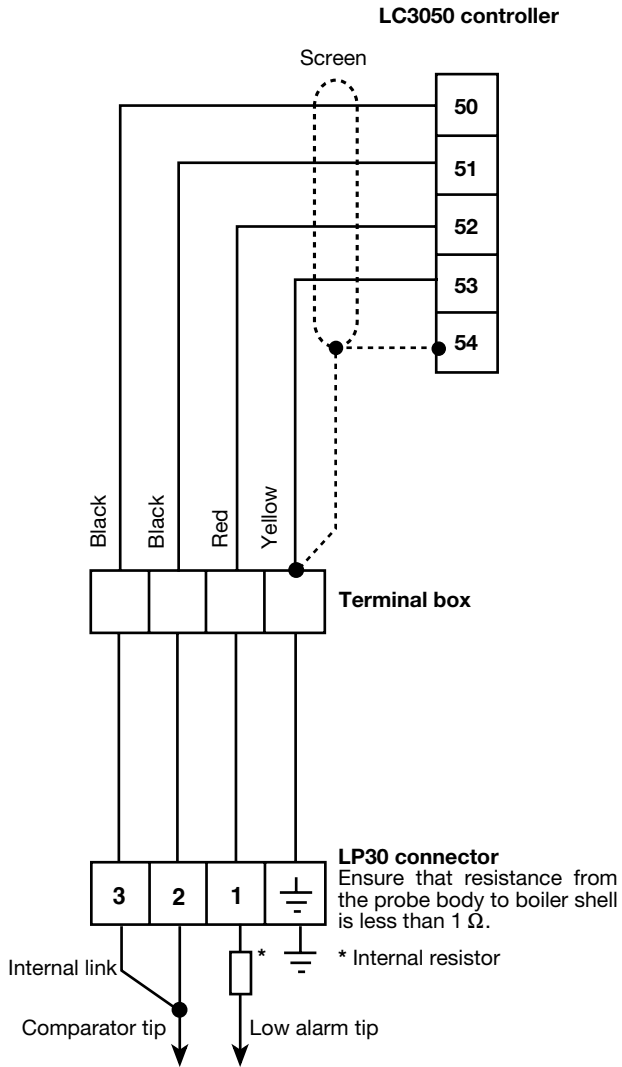

**Fig. 11 UL/FM version**

# — 5. Probe clearance test procedure —

## 5.1 Introduction

To ensure safe, correct operation of the system, it is essential that the probe tip does not touch any part of the boiler or protection tube. Standards require that the probe tip has at least 14 mm ( $\frac{9}{16}$ " ) clearance.

This test confirms that the LP30 probe is installed correctly. The test must be done on initial installation, and each time the probe is removed from the boiler, e.g. for annual inspection. A pair of 'checking wires' are used in conjunction with an Insulation Resistance Tester (meter) to test if there is less than 14 mm ( $\frac{9}{16}$ " ) radial clearance from the tip end. This is indicated by a 'short circuit' (i.e. a reading less than infinity).

When correctly carried out, the test will ensure that the final probe tip position is at least 14 mm ( $\frac{9}{16}$ " ) from the protection tube. See Figure 12.

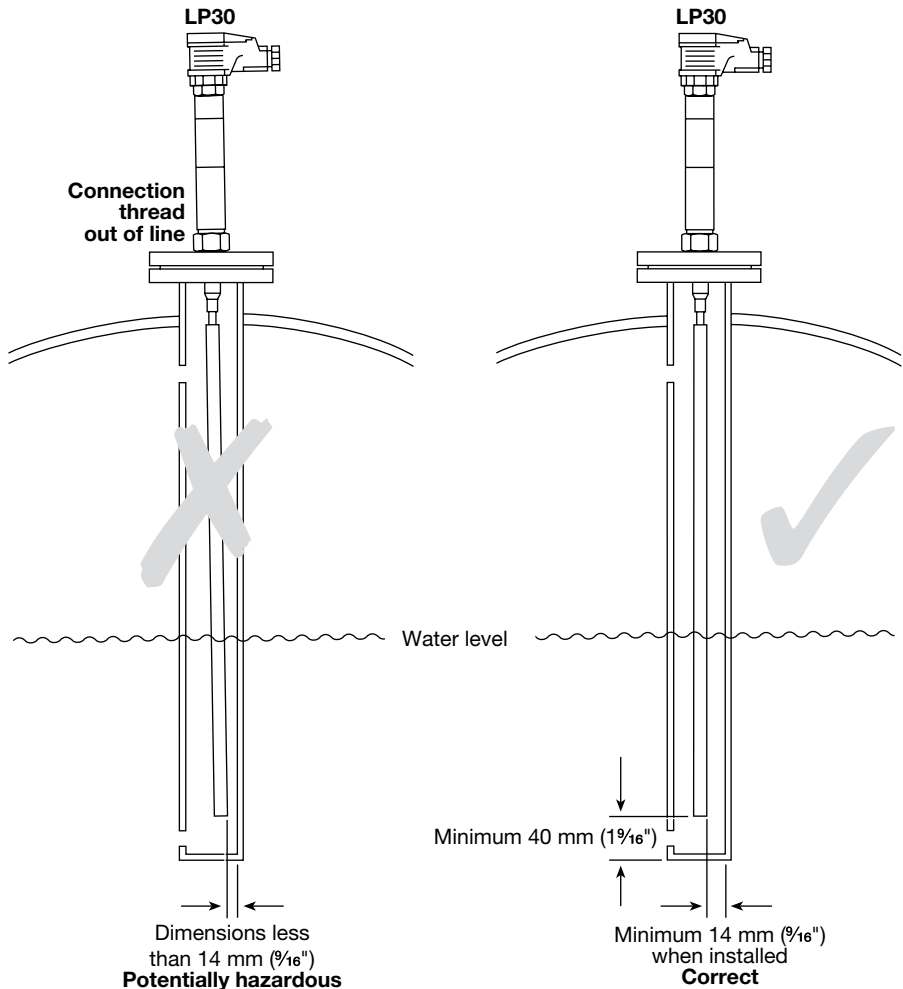

Fig. 12



## 5.2 Test method

1. Drain water level to at least 50 mm (2") below alarm level and vent boiler or vessel to atmosphere.
2. Remove probe (if installed) and fit a pair of checking wires to the end of the probe tip, 90° relative to each other and a maximum 10 mm ( $\frac{3}{8}$ ") from the tip end - see Figures 11 and 12.
3. Carefully pass probe through screwed connection and into the protection tube. The checking wires will deflect to allow them to pass through, and then spring back to their original positions.
4. Screw down probe by hand, without using PTFE tape.
5. Attach the earth lead of the meter to the boiler and the live lead to pin 1 of the probe connector. Check the contact to boiler with the meter.
6. Activate meter and observe display. Slowly unscrew probe one full turn (without unduly rocking the probe).
7. If no short circuit is found, disconnect the meter leads, unscrew and withdraw the probe, taking care not to catch the checking wires on the underside of the screwed connection.
8. Remove checking wires and install probe as described in Section 3, 'Installation'.
9. Low alarms must be functionally tested by lowering the water level before the boiler is allowed to run unsupervised. Separate literature describes this procedure.
10. Complete the clearance record sheet (see page 18 and 19).

**WARNING: It is essential to remove the checking wires from the probe before commissioning the boiler or vessel. Failure to do this could lead to the low alarms not working.**

If a short circuit was found during the test then further investigation is needed. Some possible reasons are listed below:

- Probe tip bent or not attached properly.
- Protection tube and/or screwed connection out of alignment.
- Protection tube not of large enough bore and/or not deep enough (the tube should be at least 40 mm ( $1\frac{1}{16}$ ") deeper internally than the end of the probe, see Figure 12).

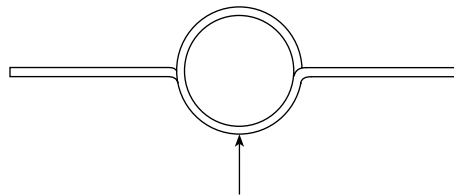

Pinch together (to relax coil)  
for fitting to probe tip

Fig. 13

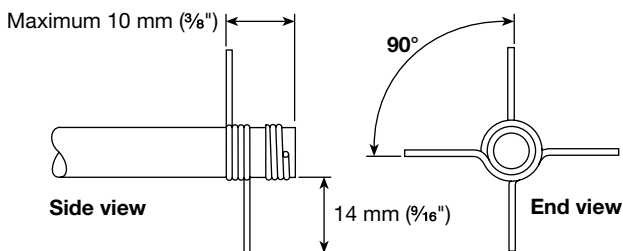

Fig. 14

---

### 5.3 Probe clearance record sheet

We strongly recommend that a record of the probe clearance test is kept, and a sheet is provided for this purpose. This must be completed each time the probe is fitted/refitted.

#### How to complete the sheet:

- **Date:** The date the test procedure was carried out.
- **Reason for test:** Initial installation or annual inspection.
- **Clearance 14 mm (9/16"):** A signature in this box signifies the test has been successfully completed, verifying the tip clearance is greater than 14 mm (9/16").
- The (competent) person who did the tests must sign this box.

Date	Reason for test



---

## 6. Maintenance

---

**Probe body cleaning instructions** - Use a cloth dampened with tap / de-ionised water or isopropyl alcohol. Use of other cleaning materials could damage the product and invalidate the warranty.

**Boiler water level controls** - Require regular testing and inspection. For specific testing instructions for Spirax Sarco systems please see separate literature.

---

## 7. Spare parts

---

The spare parts available are detailed below. No other parts are supplied as spares.

### Available spares

<b>LP30 tip retaining pins</b>	Stock No. 4024780	Pack of 10
<b>Spring clearance checking set</b>	Stock No. 4024781	1 set (2 springs)

### How to order spares

Always order spares by using the description given in the column headed 'Available spares' and state for which product they are required.

**Example:** 1 off Spring clearance checking set for a Spirax Sarco LP30 high integrity, self-monitoring low level alarm probe.